



16606063
Edition 2
May 2014

Air Drill

7A Series

Maintenance Information



Save These Instructions

IR *Ingersoll Rand*[®]

Product Safety Information

WARNING

- Failure to observe the following warnings, and to avoid these potentially hazardous situations, could result in death or serious injury.
- Read and understand this and all other supplied manuals before installing, operating, repairing, maintaining, changing accessories on, or working near this product.
- Always wear eye protection when operating or performing maintenance on this tool. The grade of protection required should be assessed for each use and may include impact-resistant glasses with side shields, goggles, or a full face shield over those glasses.
- Always turn off the air supply, bleed the air pressure and disconnect the air supply hose when not in use, before installing, removing or adjusting any accessory on this tool, or before performing any maintenance on this tool or any accessory.

Note: When reading the instructions, refer to exploded diagrams in parts Information Manuals when applicable (see under Related Documentation for form numbers).

Lubrication

Each time a Series 7A Drill is disassembled for repair or replacement of parts, lubricate the tool as follows:

1. Moisten all O-rings with O-ring lubricant.
2. Work approximately 1.5 cc of the recommended grease into the Rear Rotor Bearing (15), Front Rotor Bearing (24) and the Spindle Bearing (40).

3. Work approximately 6 cc to 8 cc of the recommended grease into the D, H, J, JJ, K or L ratio gear train and 10 cc to 12 cc of grease into the M, N or Q ratio gear train. Grease the Planet Gear Bearings (30 and 36), the gear teeth inside the Gear Case (38) and the planet gear shafts on the Spindle (28) and Gear Head (34).

Disassembly

General Instructions

1. Do not disassemble the tool any further than necessary to replace or repair damaged parts.
2. Whenever grasping a part in a vise, always use leather-covered or copper-covered vise jaws to protect the surface of the part and help prevent distortion. This is particularly true of threaded members and housings.
3. Do not remove any part which is a press fit in or on a subassembly unless the removal of that part is necessary for repairs or replacement.
4. Do not disassemble the tool unless you have a complete set of new gaskets and O-rings for replacement.
5. Do not press any needle bearing from a part unless you have a new needle bearing on hand for installation. Needle bearings are always damaged during the removal process.

Disassembly of the Gearing

1. **For N or Q ratio**, loosen the Pinch Bolt (47) and remove the Dead Handle Assembly (46) and Handle Adapter (45).
2. Remove the Drill Chuck (44) by inserting the short leg of a 1/4" hex key into the Chuck and tightening the Chuck. Rap the long leg of the key sharply with a hammer to remove the Chuck.
3. Being careful not to distort the Motor Housing (1), grasp the flats on the Housing in leather-covered or copper-covered vise jaws with the Gear Case (38) facing upward.
4. Using a wrench on the flats of the Gear Case, loosen, but do not remove the Gear Case.

NOTICE

In the following step, be sure to hold the tool over a workbench so that you will not drop or lose parts.

5. Remove the tool from the vise and, while holding the tool horizontally, carefully unscrew the Gear Case and pull it away from the Motor Housing.
6. **For D ratio**, hold the Gear Case horizontally and lightly tap the chuck end of the Spindle (28) with a plastic hammer to remove the Spindle and Drive Plate (33).
For H, J, JJ, K or L ratio, hold the Gear Case horizontally and lightly tap the chuck end of the Spindle (28) with a plastic hammer to remove the Spindle and Spindle Planet Gear Assemblies (29).
H, J and JJ ratios have a Rotor Pinion (31) and Rotor Pinion Spacer (32) that may come out with the Spindle, or they may have remained with the Rotor (19) when the Gear Case was withdrawn.
For M, N or Q ratio, hold the Gear Case horizontally and lightly tap the chuck end of the Spindle (28) with a plastic hammer to

- remove the Gear Head (34), Gear Head Planet Gear Assemblies (35), Gear head Spacer (37), Spindle and Spindle Planet Gear Assemblies (29). M and N ratios have a Rotor Pinion (31) and Rotor Pinion Spacer (32) that may come out with the Spindle, or they may have remained with the Rotor (19) when the Gear Case was withdrawn.
7. Withdraw the Spindle Planet Gear Assemblies and/or Gear Head Planet Gear Assemblies from the Spindle and/or Gear Head.
8. If it is necessary to remove the Spindle Bearing (40) from the front of the Gear Case, use a pair of internal snap ring pliers to remove the Spindle Bearing Retainer (41). Remove the Bearing Seal (42).
9. **Do not remove the Spindle Bearing from the Gear Case unless it is absolutely necessary and you have a new Bearing for replacement.** If you must remove the Bearing from the Gear Case, stand the Gear Case on the table of an arbor press, chuck end upward. Using a brass rod that will enter the front of the Gear Case, press the Spindle Bearing from the Gear Case.
10. **For H, J, JJ, M or N ratios**, if the Rotor Pinion remained on the Rotor when the Gear Case was separated from the Housing, Withdraw the Rotor Pinion along with the Rotor Pinion Spacer.

Disassembly of the Motor

1. Remove the Bearing Housing Spacer (27), Front Rotor Bearing Housing (25) and the two Bearing Spring Washers (26) from the Motor Housing (1).
2. Grasp the splined end of the Rotor (19) and pull the assembled motor from the Motor Housing.
3. Remove the Rear End Plate Gasket (16) from the Motor Housing.

WARNING

In the following step, make certain the Rear End Plate Retainer (18) doesn't spring away when it is slipped off the hub of the Rotor.

4. Using a pair of external snap ring pliers and just the tips of the pliers inserted between the ends of the Rear End Plate Retainer, spread the Retainer enough to remove it from the groove in the hub of the Rotor.
5. Withdraw the Rear End Plate (17), Cylinder (21) and Vanes (20).
6. Check the Front Rotor Bearing (24) for damage or roughness. If replacement is necessary, support the Front End Plate (22) between two blocks of wood on the table of an arbor press and press the Rotor from the Bearing.
7. Check the Rear Rotor Bearing (15) for damage or roughness. Do not remove the Rear Rotor Bearing unless you have a new Bearing on hand for replacement. The old Bearing will be damaged during the removal process. To remove the Rear Rotor

Bearing, thread a No. 10-24 x 2" long cap screw, having at least 1/2" of thread, through the Rear Rotor Bearing Nut (14) located behind the Bearing. Keep tightening the screw to jack the Bearing out of the Housing.

Disassembly of the Pistol Grip Motor Housing

1. Carefully grasp the Motor Housing (1) in leather-covered or copper-covered vise jaws so that the handle is upward.
2. Unscrew and remove the Inlet Bushing Assembly (8).
3. Remove the Muffler Assembly (11) and Muffler O-ring (12) from the Muffler Assembly.
4. Withdraw the Air Strainer Screen (9), Throttle Valve Spring (7) and Throttle Valve (6) from the housing handle.
5. Withdraw the Trigger Assembly (3).
6. Remove the Muffler Element (13).

NOTICE

In the following step, only remove the Throttle Valve Seat (5) when replacing it or when the Trigger Bushing (2) must be replaced.

Assembly

General Instructions

1. Always press on the **inner** ring of a ball-type bearing when installing the bearing on a shaft.
2. Always press on the **outer** ring of a ball-type bearing when installing the bearing in a bearing recess.
3. Whenever grasping a tool or part in a vise, always use leather-covered or copper-covered vise jaws. Take extra care with threaded parts and housings.
4. Except for bearings, always clean every part and wipe every part with a thin film of oil before installation.
5. Check every bearing for roughness. If an open bearing must be cleaned, wash it thoroughly in a suitable cleaning solution and dry with a clean cloth. **Sealed or shielded bearings should never be cleaned.** Work grease thoroughly into every open bearing before installation.
6. Apply a film of O-ring lubricant to every O-ring before installation.
7. Unless otherwise noted, always press on the stamped end of a needle bearing when installing a needle bearing into a bearing recess. Use a bearing inserting tool similar to the one shown in Dwg. TPD786.

Needle Bearing Inserting Tool

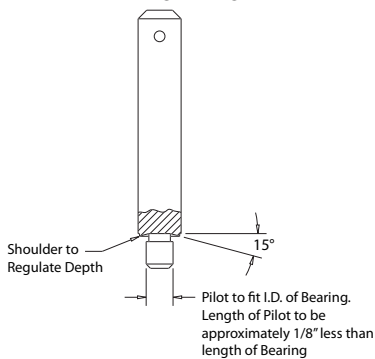

(Dwg. TPD786)

7. To remove the Throttle Valve Seat, insert a wire hook through the central hole of the Seat and hooking the underside of the Seat, pull the Seat out of the Motor Housing.
8. Before removing the Trigger Bushing, all Seals and components must be removed from the Motor Housing.
 - a. Reposition the Motor Housing in leather-covered or copper-covered vise jaws with the Trigger Bushing upward.

CAUTION

In the following step, apply enough heat to warm the Housing, but do not exceed 200 degrees Fahrenheit. Do not apply heat directly to the Skinsulate covering. Take all precautions necessary to avoid being burned during the following procedure.

- b. Using a torch, apply heat to the Motor Housing around the Bushing.
- c. Thread a 10-32 tap into the Bushing and pull the Bushing out of the Housing with the tap.

Assembly of the Pistol Grip Motor Housing

1. If the Trigger Bushing (2) was removed, proceed as follows:
 - a. Put a few drops of sealant on the end of a thin stick and insert the stick into the trigger bushing hole of the Motor Housing (1). Work the stick so that the Sealant flows against the shoulder inside the Housing.
 - b. Insert the Trigger Bushing into the Motor Housing to a depth approximately one-half the length of the Bushing.
 - c. Put a few drops of sealant in the counterbore surrounding the outside diameter of the Bushing.
 - d. Rotate the Bushing approximately 180 degrees to make certain the Sealant makes complete contact around the outside of the Bushing.
 - e. Push the Bushing into the Housing until it bottoms against the shoulder inside the Housing.
 - f. Allow the Sealant to cure for eight hours at room temperature.
2. Carefully grasp the Motor Housing in leather-covered or copper-covered vise jaws, inlet end facing upward.
3. If the Throttle Valve Seat (5) was removed, use a flat-faced rod 1/2" (13 mm) in diameter by 3" (76 mm) long to push the Seat into the Motor Housing until it seats.
4. Press the Trigger (3) onto the grooved end of the Trigger Pin so that it is at right angles to the hole in the opposite end of the Pin.
5. Insert the Trigger Assembly into the Trigger Bushing so that the hole in the Trigger Pin aligns dead center with the hole in the Throttle Valve Seat.
6. Fold or roll the Muffler Element (13) and work it into the exhaust cavity in the handle of the Motor Housing.
7. Using needle nose pliers to hold the short stem end of the Throttle Valve (6), install the Valve inserting the long stem end through the hole in the Throttle Valve and Trigger Pin.
8. Place the Air Strainer Screen (9), closed end first, inside the large end coil of the Throttle Valve Spring (7).
9. Insert the Throttle Valve Spring and Screen, small coil end first, so that the Spring encircles the end of the Throttle Valve.
10. Apply a thin coat of O-ring lubricant to the Muffler O-ring (12) and install the O-ring on the hub of the Muffler (11).
11. Install the Inlet Bushing Spacer (10) in the large hole in the Muffler Assembly (11).
12. Place the Muffler Assembly on the face of the handle so that the hub with the Muffler O-ring extends into the handle.
13. Thread the Air Inlet Bushing (8) into the large hole in the Muffler Assembly. Tighten the Bushing to a minimum of 25 ft-lb (34 Nm) torque.

Assembly of the Motor

1. If the Rear Rotor Bearing (15) was removed, install a new one as follows:
 - a. Place the Rear Rotor Bearing Nut (14) in the bore at the bottom of the bearing recess in the Motor Housing (1).
 - b. Using a needle bearing inserting tool that has a pilot extending into the Bearing, and a shoulder that contacts the outer radius on the bearing shell, press the Rear Rotor Bearing, unstamped end first, into the bearing recess until it is about 0.010" (0.25 mm) below flush.
 - c. Inject a little grease into the Bearing.
2. Slide the Front End Plate (22), flat side first, over the splined end of the Rotor (19).
3. Using a sleeve that contacts only the inner ring of the Front Rotor Bearing (24), press the Front Rotor Bearing onto the splined hub of the Rotor until it seats against the Front End Plate.
4. The clearance between the Front End Plate and Rotor is critical. While holding the Front End Plate, gently tap the front end of the Rotor until you can insert a 0.001" feeler gauge or shim between the face of the Rotor and End Plate.
5. Grasp the splined end of the Rotor in leather-covered or copper-covered vise jaws with the short hub of the Rotor upward.
6. Wipe each Vane (20) with a film of light oil and place a Vane in each slot in the Rotor.
7. Place the Cylinder (21), air port end trailing, down over the Rotor and against the Front End Plate.
8. Place the Rear End Plate (17), flat side first, over the short hub of the Rotor.

WARNING

When performing the next step, make certain the Rear End Plate Retainer (18) does not spring away as you slip it onto the hub of the Rotor.

9. Install the Rear End Plate Retainer in the groove on the rotor hub.
10. Smear a film of light grease on the Rear End Plate Gasket (16) and place the Gasket on the End Plate so that the port in the Gasket is aligned with the port in the End Plate.
11. Using an assembly dowel 3/32" in diameter by 10" long (2.3 mm x 254 mm), align the dowel holes in the Front End Plate, Cylinder and Rear End Plate. Insert the assembly rod through the aligned holes so that about 3" (76 mm) of the rod extends beyond the Rear End Plate. Insert the extension into the dowel hole at the bottom of the housing bore, and slide the motor into the Motor Housing until it seats.
12. Withdraw the assembly dowel and insert the Cylinder Dowel (23) until the Cylinder Dowel is slightly below the surface of the Front End Plate.
13. Place the two Bearing Spring Washers (26) inside the Front Rotor Bearing Housing (25).
14. Slide the Front Rotor Bearing Housing over the Front Rotor Bearing.

Assembly of the Gearing

1. Using a sleeve that contacts only the outer ring of the Bearing, press the Spindle Bearing (40) into the Gear Case (38) until it seats.
2. Place the Grease Shield (42) against the Spindle Bearing so that the outer rim of the Grease Shield slides over the outer ring of the Bearing.
3. Using snap ring pliers, install the Spindle Bearing Retainer (41) in the groove behind the Bearing and Grease Shield.
4. If the Spindle Planet Gear Bearings (30) or Gear Head Planet Gear Bearings (36) were removed, press a new Bearing into each Spindle Planet Gear (29) or Gear Head Planet Gear (35) using a bearing inserting tool that has a pilot and that contacts the outer radius of the Bearing. Press against the stamped end of the Bearing.
5. Work a small amount of the recommended grease into the gear teeth in the Gear Case.
6. Insert the Spindle, threaded end first, into the Gear Case and

through the bore of the Spindle Bearing.

7. **For D ratio**, align the three holes in the Drive Plate (33) with the spindle gear shafts and install the Drive Plate on the shafts.
For all other ratios, grease the bearings and gears of the Spindle Planet Gear Assemblies (29) and install them on the pins of the Spindle.
8. **For M, N or Q ratio**, install the Gear Head Spacer (37) in the Gear Case against the Spindle Planet Gears.
9. **For M, N or Q ratio**, grease the splined hub of the Gear Head (34) and insert it into the Gear Case. The splined hub must pass through the Gear Head Spacer and mesh with the teeth of the Spindle Planet Gears.
10. **For M, N or Q ratio**, grease the bearings and gears of the Gear Head Planet Gear Assemblies (35) and install them on the pins of the Gear Head.
11. **For H, J or JJ ratio**, grease the Rotor Pinion (31) and install it in the center of the Spindle Planet Gears. Make certain the teeth of the Pinion and Planet Gears mesh.
For M, N or N ratio, grease the Rotor Pinion (31) and install it in the center of the Gear Head Planet Gears. Make certain the teeth of the Pinion and Planet Gears mesh.
12. **For H, J, JJ, M or N ratio**, slide the Rotor Pinion Spacer (32) onto the splined shaft of the Rotor.
13. Install the Bearing Housing Spacer (27) against the gearing or Drive Plate in the Gear Case.
14. Thread the assembled Gear Case onto the assembled Motor Housing until it is hand tight. Make certain the gear teeth on the Spindle mesh with the gear teeth of the Rotor Pinion, Gear Head Planet Gears or Spindle Planet Gears.

NOTICE

After hand tightening the Gear Case, run the motor at free speed on low air pressure while final tightening the Gear Case. Listen while tightening to make certain the gears mesh properly.

15. Tighten the Gear Case between 40 and 50 ft-lb (54 and 68 Nm) torque.
16. Install the Drill Chuck Spacer (43) onto the drill spindle.
17. Thread the Drill Chuck (47) onto the drill spindle and tighten.
18. **For M or Q ratio**, install the Dead Handle Adapter (45) and Dead Handle Assembly (46) onto the front end of the Gear Case. Tighten the Pinch Bolt (47) between 10 and 20 in. lb (1.4 and 2.3 Nm) torque.

Troubleshooting Guide

Trouble	Probable Cause	Solution
Loss of Power	Low air pressure	Check air supply at the Inlet. For top performance, the air pressure must be 90 psig (6.2 bar/620 kPa) at the inlet.
	Plugged Air Strainer Screen or Inlet Screen	Clean the Air Strainer or Screen in a clean, suitable, cleaning solution. If the Screen cannot be cleaned, replace it.
	Clogged Muffler or Exhaust Silencer	Clean the Muffler Element in a clean, suitable, cleaning solution. If it cannot be cleaned, replace it.
	Worn or broken Vanes	Replace a complete set of Vanes.
	Damaged Rear End Plate Gasket	Install a new Rear End Plate Gasket.
	Worn or broken Cylinder	Replace the Cylinder if it is cracked or if the bore appears wavy or scored.
	Improper lubrication or dirt build-up	Clean the Motor Unit parts and lubricate them as instructed.
Leaky Throttle Valve	Worn Throttle Valve and/or Throttle Valve Seat	Install a new Throttle Valve and/or Throttle Valve Seat.
	Dirt accumulation on Throttle Valve and/or Throttle Valve Seat	Pour about 3 cc of a clean, suitable, cleaning solution into the air inlet and operate the tool for about 30 seconds. Immediately , pour 3 cc of the recommended oil into the air inlet and operate the tool for 30 seconds to lubricate all the cleaned parts.
Gear Case gets hot	Excessive grease	Clean and inspect Gear Case and gearing parts and lubricate as instructed.
	Worn or damaged parts	Clean and inspect the Gear Case and Gearing. Replace worn or broken components.

Related Documentation

For additional information refer to:

Product Safety Information Manual 04580353.

Product Information Manual 03539731.

Parts Information Manual 16606055.

Manuals can be downloaded from ingersollrandproducts.com

Notes:

Notes:

ingersollrandproducts.com

© 2014 *Ingersoll Rand*

