

REVISIONS				
ZONE	LTR	DESCRIPTION	DATE	APPROVED
	C	UPDATED GEARBOX AND MODEL PER SE007245	9/7/07	AAJ <i>WD</i>

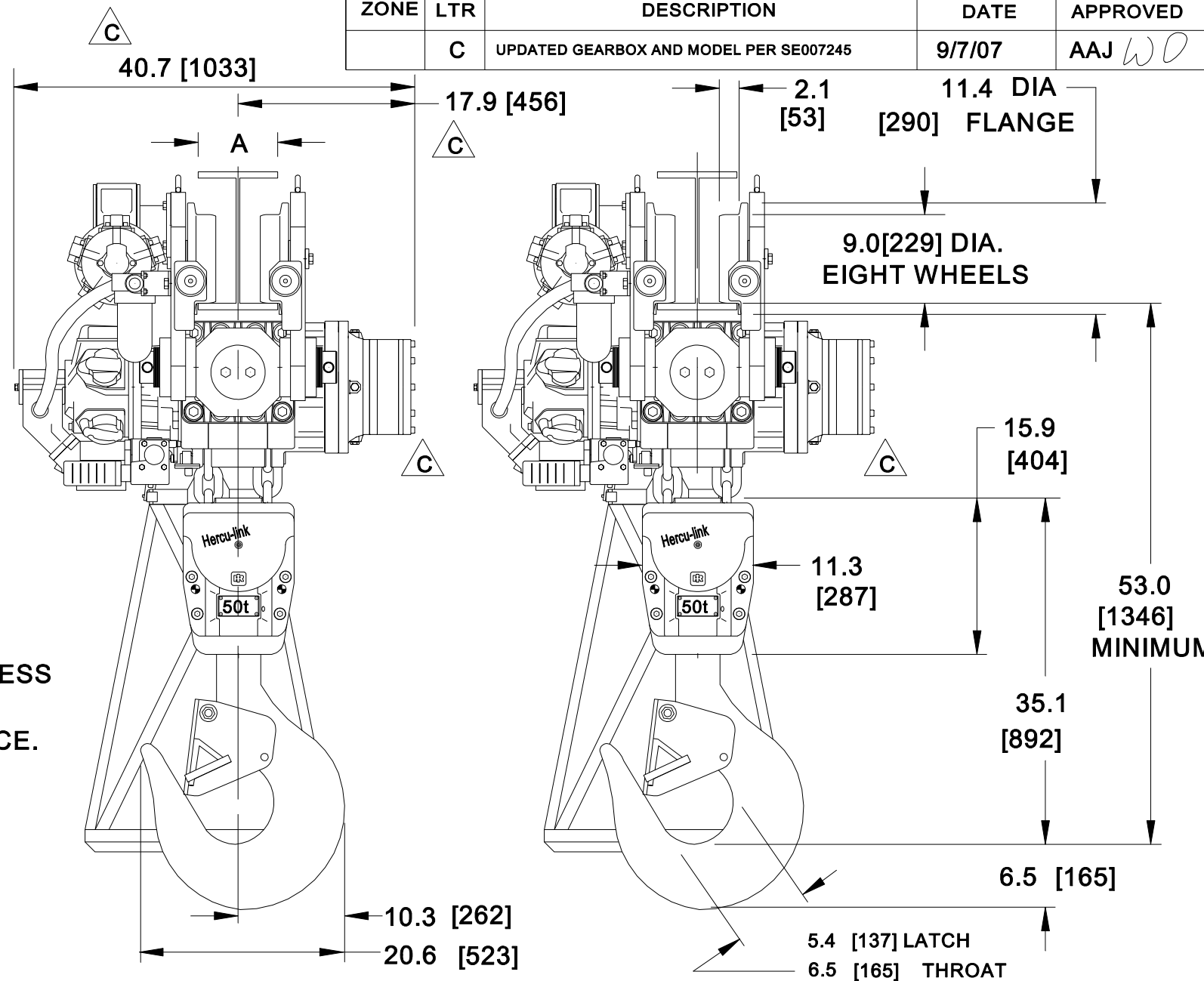
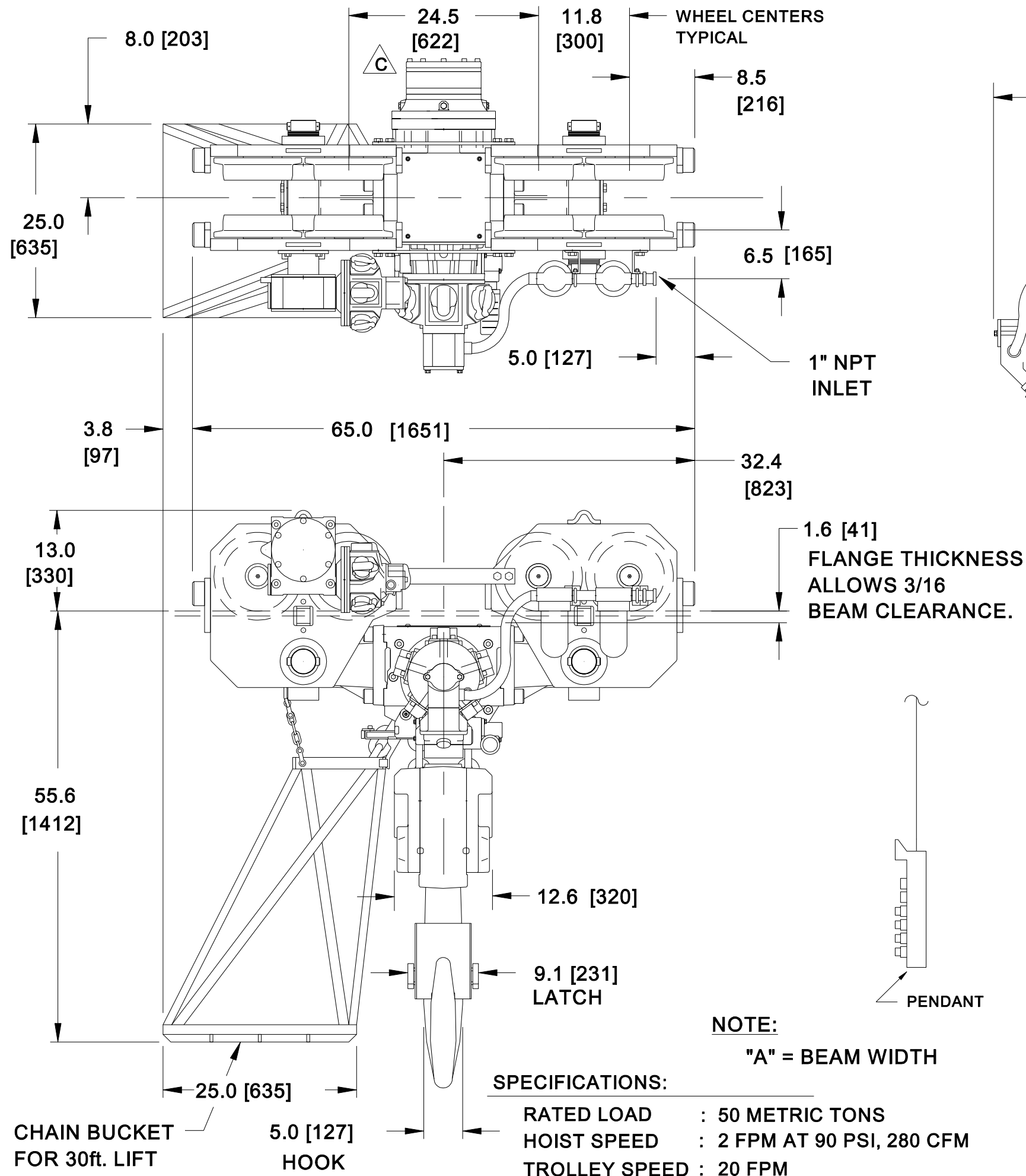

ITEM	QTY	SIZE	PART NO	DESCRIPTION
<p>THIS DOCUMENT CONTAINS CONFIDENTIAL AND TRADE SECRET INFORMATION, IS THE PROPERTY OF INGERSOLL-RAND COMPANY, AND IS GIVEN TO THE RECEIVER IN CONFIDENCE. THE RECEIVER BY RECEPTION AND RETENTION OF THE DOCUMENT ACCEPTS THE DOCUMENT IN CONFIDENCE AND AGREES THAT, EXCEPT AS AUTHORIZED IN WRITING BY INGERSOLL-RAND COMPANY, IT WILL (1) NOT USE THE DOCUMENT OR ANY COPY THEREOF OR THE CONFIDENTIAL OR TRADE SECRET INFORMATION THEREIN; (2) NOT COPY THE DOCUMENT; (3) NOT DISCLOSE TO OTHERS EITHER THE DOCUMENT OR THE CONFIDENTIAL OR TRADE SECRET INFORMATION THEREIN; AND (4) UPON COMPLETION OF THE NEED TO RETAIN THE DOCUMENT, OR UPON DEMAND, RETURN THE DOCUMENT, ALL COPIES THEREOF, AND ALL MATERIAL COPIED THEREFROM.</p> <p>WARNING: The export or reexport of this drawing or a product produced by this drawing is subject to U. S. Export Administration Regulations and other applicable governmental restrictions or regulations.</p> <p>Copyright 20__ 07 Ingersoll-Rand Company All Rights Reserved</p> <p>Ingersoll-Rand Company Tool & Hoist Division Seattle, WA. U.S.A.</p>				
<p>UNLESS OTHERWISE SPECIFIED TOLERANCES ON DIMENSIONS ARE DECIMALS: 2 PLACES:(XX)= ±.02 3 PLACES:(XXX)= ±.005 ANGLES: ±0.5° BREAK EDGES .010 SURF 125 ✓</p>				
<p>THIRD ANGLE PROJECTION</p>			<p>TITLE HOIST, AIR HERCULINK OUTLINE/DIMENSIONAL BHS100MA6-30-30 (2 UNITS REQ'D)</p>	
<p>DRAWN DATE RPP 10/04 1993</p>		<p>SIZE PART NO. DWG NO. REV B 22323 C</p>		
<p>CHECKED</p>		<p>SCALE: 1:16</p>		
<p>APPROVED</p>		<p>SHEET 1 OF 1</p>		
<p>ENG APPVL <i>GA</i> 10/04 1993</p>				