



04584264
Edition 3
January 2014

Air Impact Wrench

2920B Series

Maintenance Information



Save These Instructions

IR Ingersoll Rand®

Product Safety Information

WARNING

- Failure to observe the following warnings, and to avoid these potentially hazardous situations, could result in death or serious injury.
- Read and understand this and all other supplied manuals before installing, operating, repairing, maintaining, changing accessories on, or working near this product.
- Always wear eye protection when operating or performing maintenance on this tool. The grade of protection required should be assessed for each use and may include impact-resistant glasses with side shields, goggles, or a full face shield over those glasses.
- Always turn off the air supply, bleed the air pressure and disconnect the air supply hose when not in use, before installing, removing or adjusting any accessory on this tool, or before performing any maintenance on this tool or any accessory.

Note: When reading the instructions, refer to exploded diagrams in Parts Information Manuals when applicable (see under Related Documentation for form numbers).

Lubrication

Each time a Model 2920B and 2920B9 Impactool is disassembled for maintenance and repair or replacement of parts, lubricate the tool as follows:

1. Work 12 to 15 cc of **Ingersoll Rand** No. 170 Grease into the impact mechanism. Coat the Anvil (45, 47, 48, 50, 53 or 56) lightly with grease around the Hammer Case Bushing (38 or 41). Inject 2 to 4 cc of grease into the Grease Fitting (10 or 18).

2. Use **Ingersoll Rand** Oil No. 50 for lubricating the motor. Inject 1 to 2 cc of oil into the air inlet before attaching the air hose. Remove the Oil Chamber Plug (16 or 10) and fill the oil chamber.

Disassembly

General Instructions

1. Do not disassemble the tool any further than necessary to replace or repair damaged parts.
2. Whenever grasping a tool or part in a vise, always use leather-covered or copper-covered vise jaws to protect the surface of the part and help prevent distortion. This is particularly true of threaded members and housings.
3. Do not remove any part which is press fit in or on a subassembly unless the removal of that part is necessary for repairs or replacement.
4. Do not disassemble the tool unless you have a complete set of new gaskets and O-rings for replacement.

Model 2920B

Disassembly of the Square Drive Anvil and Spline Drive Anvil

1. Clamp the handle of the Impactool in leather-covered or copper-covered vise jaws with the square drive Anvil upward.
2. Unscrew and remove the four Hammer Case Cap Screws (39).
3. While lightly tapping on the end of the Anvil (45 or 53) with a plastic hammer. Lift off the Hammer Case (37).
4. Remove and discard the Hammer Case Gasket (36).
5. Grasp the Hammer Frame (42) and carefully lift off the entire impact mechanism, making certain not to drop the two Hammer Pins (43). If it is necessary to disassemble the impact mechanism, refer to Disassembly of the Impact Mechanism. If it is unnecessary to disassemble the impact mechanism, set it aside intact.

Disassembly of the Quick-Change Anvil

1. Clamp the handle of the Impactool in leather-covered or copper-covered vise jaws with the Quick-Change Anvil upward.
2. Remove the front Thrust Ring Lock (49) and Thrust Ring (50).

NOTICE

The Retaining Ball (52) is held in the hole in the Anvil (47) by the Retaining Sleeve. Once the Retaining Sleeve is removed, the Retaining Ball will fall free.

3. Remove the Retaining Sleeve Spring (51), Retaining Sleeve, Retaining Ball, and the rear Thrust Ring Lock (49).
4. While lightly tapping on the end of the Anvil with a plastic hammer, lift off the Hammer Case (37) and remove the Hammer Case Gasket (36).
5. Grasp the Hammer Frame (42) and carefully lift off the entire impact mechanism, making certain not to drop the two Hammer Pins (43). If it is necessary to disassemble the impact mechanism, refer to Disassembly of the Impact Mechanism. If it is unnecessary to disassemble the impact mechanism, set it aside intact.

Disassembly of the Impact Mechanism

1. Set the mechanism, driver end up, on the workbench.

NOTICE

Note the twin Hammers (44) within the Hammer Frame (42). These are identical but must be placed in the Hammer Frame in a certain relationship. Using a felt-tipped pen, mark the top Hammer "T ↑" and the bottom Hammer "B ↑" with the arrows pointing upward. Mark both Hammers on the same end.

2. With the mechanism sitting upright on the workbench, slowly rotate the Anvil (45 or 47) in a clockwise direction until it comes up solid.

NOTICE

If you continue to rotate the Anvil, it will cam the Hammers out of engagement. Do not allow this to happen; merely rotate the Anvil until it comes up solid.

3. Hold the Hammer Frame firmly and, without disturbing the Hammers, gently lift the Anvil, simultaneously rotating it counterclockwise about 1/8 of a turn, from the Hammer Frame.

NOTICE

The twin Hammers will be free to slide from the Hammer Frame when the Hammer Pins (43) are removed. Do not drop the Hammers.

4. With the Anvil removed, lift out the two Hammer Pins.
5. Remove the Hammers.

Disassembly of the Reverse Valve

NOTICE

The Reverse Valve Knob Screw (20) is installed with a thread locking compound. You may have to heat the Screw slightly to loosen it.

1. Unscrew the Reverse Valve Knob Screw and remove the Reverse Valve Knob (19).

NOTICE

For models with optional Power Regulator Part No. 2920-K329 only, be careful not to lose the Reverse Valve Detent Ball (21) and Reverse Valve Detent Ball Spring (22) from the hole in the side of the Reverse Valve (17).

2. While slowly rotating the Reverse Valve, withdraw it from the reverse valve bushing in the Motor Housing.

Disassembly of the Motor

1. Grasp the Motor Retainer (35) and remove it from the Motor Housing (1).
2. Remove the Rear Hammer Frame Washer (41) and the Motor Clamp Washers (34) from the front of the Motor.

NOTICE

The End Plate Dowel (30) will fall free when the Front End Plate (29) clears the Housing. Do not lose the Dowel.

3. Grasp the splined end of the Rotor (31), carefully lift the assembled motor from the Motor Housing.
4. Remove the Rear End Plate Gasket (26).
5. Remove the Motor Housing from the vise.
6. Slide the Front End Plate (29) with the Front Rotor Bearing (32) from the Rotor.
7. Remove the Cylinder Dowel (33), Cylinder (27) and Vanes (28) from the Rotor.
8. Using snap ring pliers, remove the Rear Rotor Bearing Retainer (23) and slide the Rear End Plate (25) with the Rear Rotor Bearing (24) from the Rotor.
9. If the Front or Rear Rotor Bearing requires replacement, press it from the End Plate.

Disassembly of the Throttle Mechanism

1. Unscrew the Air Inlet Bushing (9) and remove the Air Strainer Screen (8), Throttle Valve Spring (7),
2. Throttle Valve Assembly (5) and Throttle Valve Plunger (4).
3. If the Throttle Valve Seat (6) needs replacement, insert a hooked tool through the center of the Valve Seat. Catch the backside of the Seat with the hook and pull the Seat from the Housing.
4. Unscrew the four Exhaust Deflector Screws (15) and remove the Exhaust Deflector (13) Exhaust Deflector Gasket (14) and the Exhaust Silencer/Exhaust Baffle (12, 11) combination.

Model 2920B9

Disassembly of the Angle Attachment

1. Slide the Connector Retaining Sleeve (116) toward the square drive anvil and pull the Angle Housing Assembly (102) off the tool.

Assembly

General Instructions

1. Always press on the **inner** ring of a ball-type bearing when installing the bearing on a shaft.
2. Always press on the **outer** ring of a ball-type bearing when pressing the bearing into a bearing recess.
3. Whenever grasping a tool or part in a vise, always use leather-covered or copper-covered vise jaws. Take extra care with threaded parts and housings.
4. Always clean every part and wipe every part with a thin film of the recommended oil before installation.
5. Apply a film of O-ring lubricant to all O-rings before final assembly.

Assembly of the Throttle Mechanism

1. Sandwich the Exhaust Baffle (11) between the two Exhaust Silencers (12) and install them in the rectangular opening in the bottom of the Motor Housing (1).
2. Install the Exhaust Deflector Gasket (14) on the rim of the opening.
3. Place the Exhaust Deflector (13) over the Gasket and after applying a thread locking compound to the four Exhaust Deflector Screws (15), secure the Deflector with the Screws. Tighten each Screw to 20 to 25 in-lb (2 to 3 Nm) torque.
4. Apply a thin coat of O-ring lubricant to the Throttle Valve Face (6). Using a dowel, seat the Valve securely and without damage.
5. Install the Throttle Valve on the small end of the Throttle Valve Plunger (4) and insert the Plunger and Valve, Plunger first, into the air inlet chamber of the housing.

NOTICE

Be careful not to lose the three Connector Retaining Balls (119) as they are free to fall out when the Connector Retaining Sleeve is removed.

2. Grasp the Angle Housing Assembly in leather-covered or copper-covered vise jaws, bevel pinion end facing upward. Slide the Connector Retaining Sleeve (116) toward the square drive anvil and remove the Connector Retaining Sleeve Stop (118) from the Angle Housing Connector (114).
3. Working over a workbench, carefully slide the Connector Retaining Sleeve off the Angle Housing Connector.
4. Slide the Retaining Sleeve Spring (117) off the Angle Housing Connector.
5. Using a thin blade screwdriver, pry the two Connector Lock Pins (115) from the Housing.
6. Using a spanner wrench in one of connector lock pin holes, unscrew and remove the Angle Housing Connector (114).
7. Pull the Bevel Pinion Driver (109) off the Bevel Pinion Assembly (104).
8. Slide the Bevel Pinion Assembly, four Bevel Pinion Clamp Washers (110), Bevel Pinion Bearing (107) and Bevel Pinion Spacer (108) from the Angle Housing Assembly. Remove the Angle Housing from the vise.
9. Grasp the Angle Housing in leather-covered or copper-covered vise jaws, Bevel Gear (111) facing upward.
10. Using snap ring pliers, remove the Bevel Gear Bearing Retainer (113).
11. Slide the Bevel Gear Bearing (107), Bevel Gear, and Bevel Gear Spindle (112) from the Angle Housing. Remove the Angle Housing from the vise.

NOTICE

Further disassembly of the Model 2920B9 Impacttool is identical to Model 2920B.

6. Put the small end of the Throttle Valve Spring (7) over the trailing end of the Throttle Valve. Place the Air Strainer Screen (8) so that it sits within the coils of the Spring and install the Air Inlet Bushing (9). Tighten the Inlet Bushing to 50 to 60 ft-lb (68 to 81 Nm) torque.

Assembly of the Motor

1. Using a sleeve that will contact only the outer ring of the bearing, press the Front Rotor Bearing (32) into the Front End Plate (29) and the Rear Rotor Bearing (24) into the Rear End Plate (25).
2. Slip the Front End Plate and Bearing over the splined hub of the Rotor (31).
3. Grasp the splined end of the Rotor in leather-covered or copper-covered vise jaws with the Rotor in a vertical position.
4. Dampen each Vane (28) with light oil and insert a Vane into each vane slot in the Rotor.
5. Set the Cylinder (27) over the Rotor and onto the Front End Plate.
6. Slide the Rear End Plate and Bearing onto the Rotor hub and against the Cylinder.
7. Using snap ring pliers, install the Rear Rotor Bearing Retainer (23) in the groove on the rotor hub.
8. Align the dowel hole in both End Plates with the one through the Cylinder, and insert a guide rod 3/16" x 8" (4.7 mm x 203 mm) through the holes. Allow the rod to protrude about 3-1/2" (89 mm) from the Rear End Plate.
9. While holding the assembled motor intact, remove it from the vise.

10. Insert the protruding end of the guide rod into the cast slot at the bottom of the Motor Housing bore and slide the assembled motor along the rod until it is completely seated in the housing.
11. Remove the guide rod and install the Cylinder Dowel (33).
12. Install the End Plate Dowel (30).
13. Grasp the handle of the Motor Housing in leather-covered or copper-covered vise jaws with the open end of the Motor Housing upward.
14. Place a Motor Clamp Washer (34), concave side first, down over the hub of the Front End Plate so that the outer rim of the Washer contacts the Front End Plate. Place the second Motor Clamp Washer, convex side first, down over the hub of the Front End Plate so that the inner rims of both Washers are in contact but the outer rims are separated.
15. Place the Motor Retainer (35), small bore first, down over the hub of the Front End Plate and against the outer rim of the second Motor Clamp Washer.

Assembly of the Reverse Valve

1. After applying O-ring lubricant to the Reverse Valve Seals (18), install them in the undercuts in the reverse valve bushing. Make certain they are properly seated.
2. Dampen the Reverse Valve (17) with light oil. **For models with optional Power Regulator Part No. 2920-K329 only**, install the Detent Spring (22) followed by the Reverse Valve Detent Ball (21) in the hole in the Reverse Valve. With the Impactool in an upright horizontal position, and while facing the handle end of the impactool, insert the Reverse Valve from left to right into the reverse valve bushing.
3. **For models with optional Power Regulator Part No. 2920-K329 only**, position the Reverse Valve with the indicator slot on the end of the Valve pointing to the number 5 on the Housing. Position the Reverse Valve Knob (19) on the opposite end of the Valve with the small notch pointing, as near as possible, to the number 5 on that side of the Housing. Apply a thread locking compound to the Reverse Valve Knob Screw (20) and fasten the Knob to the Valve with the Screw. Tighten the Knob Screw to 5 to 6 ft-lb (6.75 to 8.15 Nm) torque.

Assembly of the Impact Mechanism

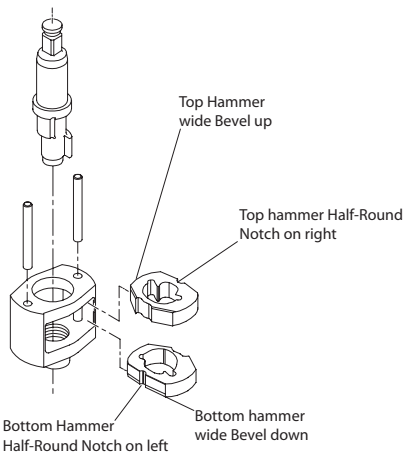

(Dwg. TPD652)

1. Coat the Hammers (44) with a light film of **Ingersoll Rand No. 170 Grease**.

2. Replace the Hammers in the Hammer Frame (42) exactly as they were when you marked them prior to disassembly.

NOTICE

If you are installing new Hammers, or want to change the location of the existing Hammers to utilize both impacting surfaces, slide the Hammers in the Hammer Frame so that the half-round notch on one Hammer is located on one side of the Frame and the half-round notch on the other Hammer is located on the other side of the Frame. These Hammers must be installed with the wide bevels facing the web of the Hammer Frame as illustrated.

3. Replace the Hammer Pins (43).
4. Examine the base of the Anvil and note its contour. While looking down through the Hammer Frame, swing the top Hammer to its full extreme one way or another until you can match the contour of the Anvil. Enter the Anvil into the Hammer Frame and through the first Hammer. Swing the bottom Hammer in the opposite direction from the top Hammer and maneuver the Anvil slightly until it drops into the bottom Hammer.

Model 2920B

Assembly of the Square Drive Anvil and Spline Drive Anvil

1. Place the Rear Hammer Frame Washer (41) or (44), hub side first, over the hub of the Rotor and against the Front Rotor Bearing.
2. Set the assembled impact mechanism down over the splined hub of the Rotor. If the impact mechanism was disassembled, refer to Assembly of the Impact Mechanism.
3. Position the new Hammer Case Gasket (36) or (39) on the Housing.
4. Work approximately 12 to 15 cc of **Ingersoll Rand No. 170 Grease** into the impact mechanism.
5. Smear a thin film of **Ingersoll Rand No. 170 Grease** on the inside surface of the Hammer Case Bushing (38) or (41) and place the Hammer Case (37) or (40) down over the Anvil (45 or 53) or (48 or 56) and against the Motor Retainer.
6. Install the Hammer Case Cap Screws (39) or (42) and Cap Screw Lock Washers (40) or (43) and tighten them to 20 to 25 ft-lb (27 to 34 Nm) torque.
7. Remove the Impactool from the vise and inject 2 to 4 cc of the recommended grease into the Grease Fitting (10) or (18).

Assembly of the Quick-Change Anvil

1. Place the Rear Hammer Frame Washer (41) or (44), hub side first, over the hub of the Rotor and against the Front Rotor Bearing.
2. Set the assembled impact mechanism down over the splined hub of the Rotor. If the impact mechanism was disassembled, refer to Assembly of the Impact Mechanism.
3. Position the new Hammer Case Gasket (36) or (39) on the Housing.
4. Work approximately 12 to 15 cc of **Ingersoll Rand No. 170 Grease** into the impact mechanism.
5. Smear a thin film of **Ingersoll Rand No. 170 Grease** on the inside surface of the Hammer Case Bushing (38) or (41) and place the Hammer Case (37) or (40) down over the Anvil and against the Motor Retainer.
6. Reinstall the rear Thrust Ring Lock (49) or (52) on the Quick Change Anvil (47) or (50).
7. Place a dab of grease into the hole in the Quick Change Anvil to temporarily hold the Retaining Ball (52) or (55).
8. Slide the Retaining Sleeve (48) or (51), Retaining Sleeve Spring (51) or (54), Thrust Ring (50) or (53), and front Thrust Ring Lock (49) or (52) onto the Anvil.

Model 2920B9

NOTICE

The Retaining Ball (52) is held in the hole in the Anvil (47) by the Retaining Sleeve. Once the Retaining Sleeve is removed, the Retaining Ball will fall free.

- Grasp the Angle Housing (102) in leather-covered or copper-covered vise jaws, bevel gear end facing upward.
- Coat the Bevel Gear Spindle (112) with **Ingersoll Rand No. 170 Grease** and insert the Spindle into the bushing of the angle head.
- Install the Bevel Gear (111) and Bevel Gear Bearing (107).
- Using snap ring pliers install the Bevel Gear Bearing Retainer (113) into the groove in the angle head. Remove the Angle Housing from the vise.
- Grasp the Angle Housing in a vise, bevel pinion end facing upward.
- Insert the bevel pinion into the Angle Housing until it meshes with the Bevel Gear. Install the Bevel Pinion Spacer (108), Bevel Pinion Bearing (107) and four Bevel Pinion Clamp Washers (110).
- Screw the Angle Housing Connector (114) into the Angle Housing and tighten the Connector using a spanner wrench inserted into one of the connector lock pin holes.
- Install the Bevel Pinion Driver (109) onto the Bevel Pinion.
- Install the two Connector Lock Pins into the two corresponding holes in the Angle Housing Connector.
- Install the Retaining Sleeve Spring (117) onto the Angle Housing until it butts against the Connector Lock Pins.
- Insert the three Connector Retaining Balls (119) into their respective holes in the Angle Housing Connector.
- Slide the Connector Retaining Sleeve (116) over the Angle Housing Connector and while pushing the Sleeve toward the square drive anvil, install the Connector Retaining Sleeve Stop (118). Remove the Angle Housing Assembly from the vise.
- Grasp the Angle Attachment and slide the Connector Retaining Sleeve toward the square drive anvil. Install the Angle Attachment on the tool in one of six different positions relative to the in-line handle. Release the Connector Retaining Sleeve to lock the Angle Attachment onto the tool.
- Inject approximately 9 cc of **Ingersoll Rand No. 170 Grease** into the Grease Fitting on the Angle Housing.

Troubleshooting Guide

Trouble	Probable Cause	Solution
Low power	Dirty Inlet Bushing or Air Strainer Screen and/or Exhaust Silencer	Using a clean, suitable, cleaning solution, in a well ventilated area, clean Air Strainer Screen, Inlet Bushing and Exhaust Silencer.
	Worn or broken Vanes	Replace complete set of Vanes.
	Worn or broken Cylinder and/or scored End Plates	Examine Cylinder and replace it if it is worn or broken or if bore is scored or wavy. Replace End Plates if they are scored.
	Dirty motor parts	Disassemble tool and clean all parts with a clean, suitable, cleaning solution, in a well-ventilated area. Reassemble tool as instructed in this manual.
	Improper positioning of Reverse Valve	Make certain that Reverse Valve is fully engaged to the left or right.
Motor will not run	Incorrect assembly of motor	Disassemble motor and replace worn or broken parts and reassemble as instructed.
	Insufficient lubricant in the impact mechanism	Remove Hammer Case Assembly and lubricate impact mechanism.
Tool will not impact	Broken or worn impact mechanism parts	Remove Hammer Case and examine impact mechanism parts. Replace any worn or broken parts.
	Impact mechanism not assembled correctly	Refer to Assembly of the Impact Mechanism .

Related Documentation

For additional information refer to:

Product Safety Information Manual 04581450.

Product Information Manual 04584793.

Parts Information Manual 04584405.

Manuals can be downloaded from ingersollrandproducts.com

Notes:

Notes:

ingersollrandproducts.com

© 2014 *Ingersoll Rand*

